

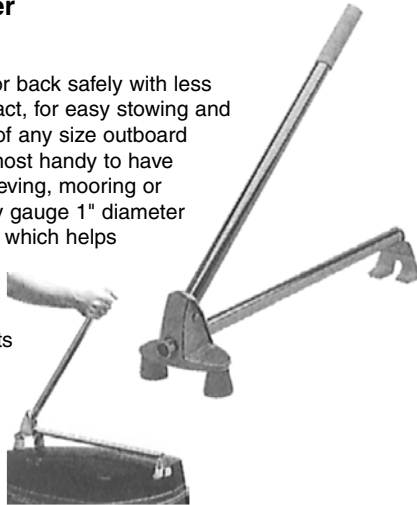

Motor Tilter

Motor Tilter. Helps to tilt motor back safely with less strain. It is lightweight, compact, for easy stowing and adjustable to fit the shrouds of any size outboard motor with hand holds. It is most handy to have aboard when launching, retrieving, mooring or beaching. It is made of heavy gauge 1" diameter ANODIZED aluminum tubing which helps prevent salt water corrosion and weathering. Durable aluminum castings are cushioned at all contact points to prevent marring. Folds flat. Handles motors to 40 h.p.



ORDER NO.	PRICE
GAR 71036	\$71.40

Doel-Fin by **DAVIS**

Doel-Fin® is the original hydrofoil developed by an aeronautical engineer to **improve overall performance on all boats with outboard motors or outdrive units.** Molded in 2 pieces of guaranteed unbreakable, high-strength plastic, each foil is designed to flex independently to absorb shock. The positive effects include greater stability, consistent planning at lower RPM, faster out-of-the-hole performance, steadier turns, higher top-end speeds and lower bow rise at all speed.

- Doel-Fin improves overall performance – even on boats with well-designed hulls
- Save up to 30% on fuel consumption
- Faster out-of-the-hole for happier water skiers
- Maintain lower planning speeds without constant throttle adjustments for wakeboarding, tubing or beginning skiers
- Less bow rise for better visibility and increased safety.



ORDER NO.	PRICE
DAV 440	\$33.99

StingRay XR III Hydrofoil

The Premier Stabilizer in the Hydrofoil line Same great added benefits as the XP II design PLUS

- No Drill Mounting Design
- Sleeker Hydrodynamic Profile
- Captive Prop-Wash Resulting in Improved Thrust
- Fastest Hole Shot of all Hydrofoils



ORDER NO.	DESCRIPTION	PRICE
MDY XR III1	Black XR III	\$157.84
MDY XR III2	White XR III	\$157.84

Junior models for up to 40HP

ORDER NO.	DESCRIPTION	PRICE
MDY JRX III1	Black	\$139.75
MDY JRX III2	White	\$139.75



Sailboat Dolly

Helps to launch most small board-type sailboats. Vinyl covered tube fits into opening of center or "dagger" board. Hull rests on poly covered supports. Made of high tensile steel tubing with 1/2" zinc plated axle. Rolls easily on 4-7" rubber tired wheels. Ideal for moving sailboats from car to waterfront at lake homes, campsites and resorts. Measures 11" H, 9-1/2" D and 5/8" W. Stable, widetrack 24" wheel span.

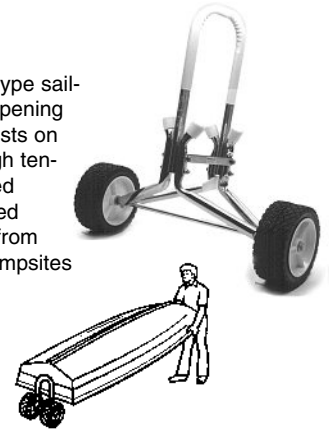

ORDER NO.	PRICE
GAR 71051	\$141.55



Boat Dolly

Helps to move and roll small fishing boats with ease. Clamps securely to the transom. Turn boat with keel up and roll it wherever desired. Utilizes 1" sturdy zinc plated steel and 4-7" rubber tired wheels mounted on 1/2" zinc plated steel axle. Ideal for moving boats from cars to water, at lake homes, campsites and resorts. Maximum weight: 250 lbs.



ORDER NO.	PRICE
GAR 71050	\$69.93

StingRay XP II Hydrofoil

Hydrofoil Stabilizer now made with Speed-XP™, an extreme performance hydrophilic material, making the worlds fastest hydrofoil stabilizer even faster! Speed-XP is a clear hydrophilic (water-absorbing) material that is thermally bonded to the base polymer material of the hydrofoil. The surface of this material is hard when dry and looks like a new wax job-however the "magic" of its performance is released when the surface becomes wet...Speed-XP™ acts like a microscopic sponge when wet and will bind a very thin layer of water to the surface of the hydrofoil. The result is running water on water – a dramatic reduction in hydrodynamic drag and improved performance.

ORDER NO.	DESCRIPTION	PRICE
MDY SRXP II1	Black XP II	\$73.63
MDY SRXP II2	White XP II	\$73.63



Junior XP II for up to 40HP

ORDER NO.	DESCRIPTION	PRICE
MDY JRXP II1	Black Junior XP II	\$57.15

StingRay Torque Equalizers

When added to the bottom of your Sting Ray Stabilizer, these torque equalizers are like adding power steering to your boat. Neutralizes steering torque; makes boat track straight. Easily installed.

ORDER NO.	PRICE
MDY TEXP1	\$16.78

