

TO: SERVICE MANAGER TECHNICIANS
PARTS MANAGER

No. 83-27

New Shift Cable (41951A1) For MerCruiser 120R-thru-260R Models

Newer production MerCruiser 120R-thru-260R Models (with transom assembly serial number 6376504 and above) will be equipped with a new style drive unit shift cable (41951A1). (Figure 1) The new style cable attaches to the bell housing from the aft end (rather than the front end as the old style cable did) for easier removal and installation. With the exception of the cable attaching method, the installation and adjustment procedure is the same as the old style cable. A 9/16", thin wall, deep well, 3/8" drive socket is required for cable removal and installation (refer to Subject "B", following).

CAUTION

Be sure to apply Quicksilver Perfect Seal (92-34227) to shift cable brass fitting prior to installation, or water leakage into bell housing may result.

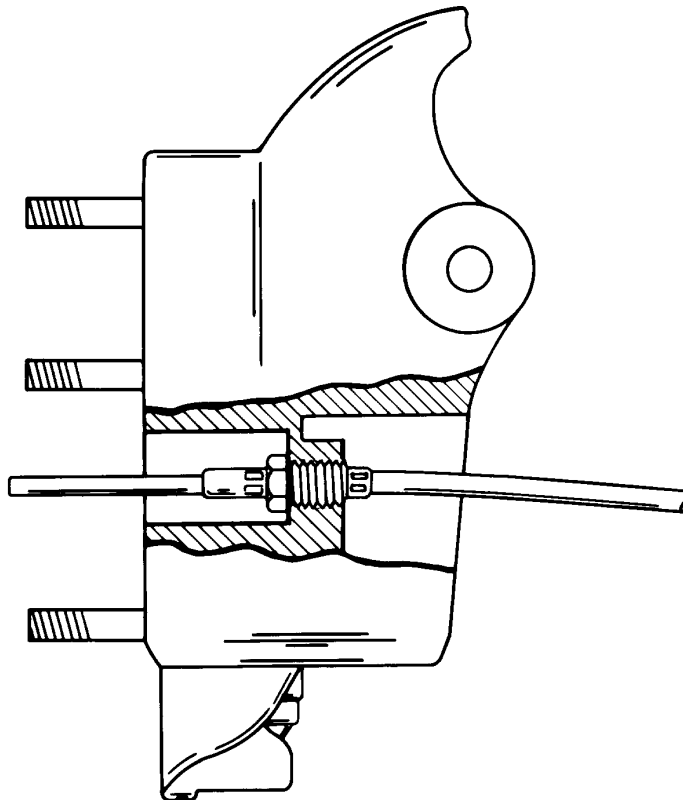
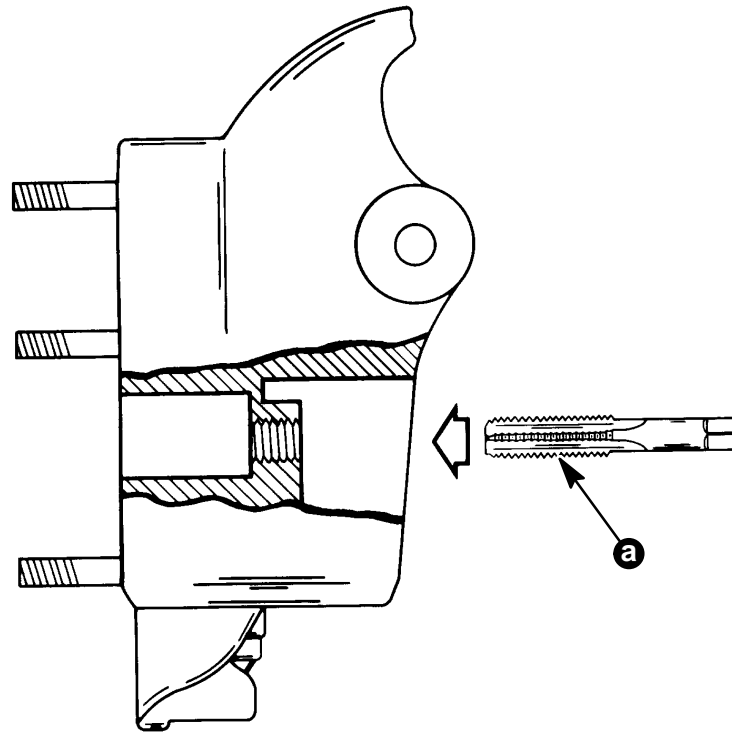

Figure 1. New Style Drive Unit Shift Cable (41951A1)

The new style cable can be used on ALL MerCruiser 120R-thru-260R Models. Cable also can be used in place of cable (73679A2) on older models if the shift cable threaded hole in bell housing is tapped all-the-way thru. (Figure 2) Tapping MUST BE done from the front end of the bell housing, using a 1/4-18 NPSF (straight thread) tap. DO NOT USE A TAPERED THREAD TAP.



a - 1/4"-18 NPSF Tap

Figure 2. Threading Shift Cable Hole in Bell Housing (Older Models)

Drive Unit Shift Cable Removal and Installation Tool

A drive unit shift cable removal and installation tool can be fabricated by welding a large nut (7/16" ID minimum) to the top of a 9/16", thin wall, deep well, 3/8" drive socket. (Figure 3) This tool can be used on both the new and old style cables. (Figures 4 and 5) When using the tool on older style cables, the cable outer casing must be removed from the gimbal housing so that the tool can be slid over the end of the cable and into position.

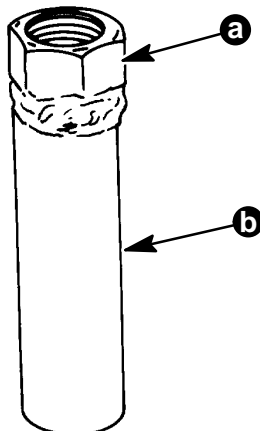

a - Nut (7/16" ID Minimum)

b - 9/16" Thin Wall, Deep Well, 3/8" Drive Socket

Figure 3. Drive Unit Shift Cable Removal and Installation Tool

16690

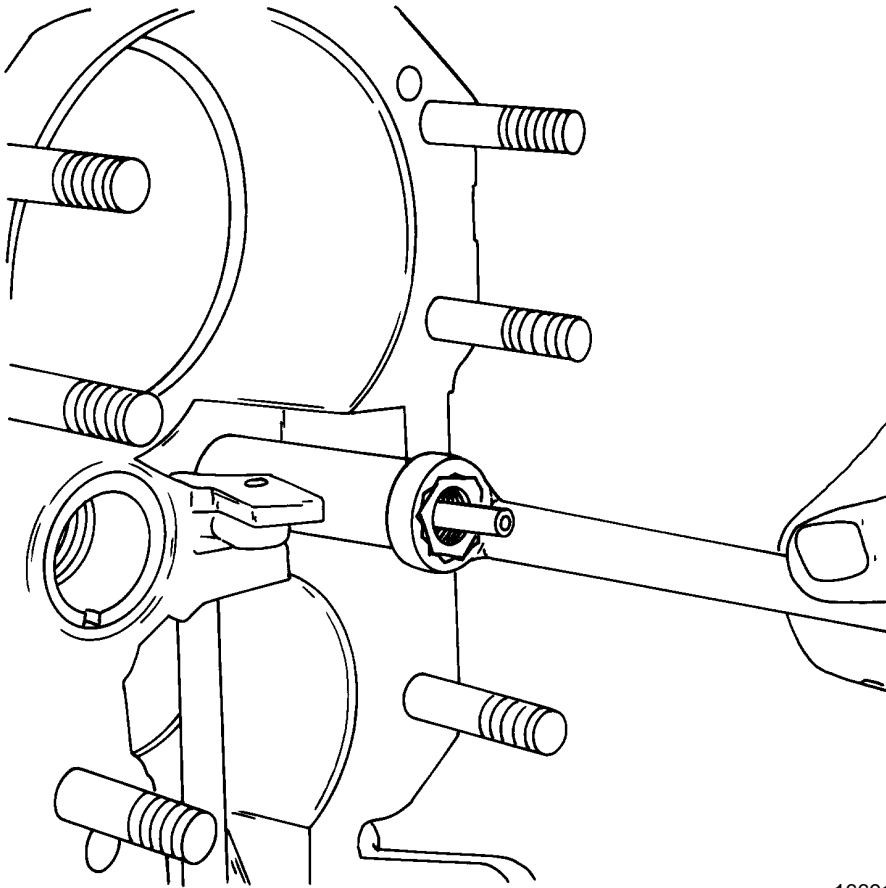

16691

Figure 4. Removing New Style Cable

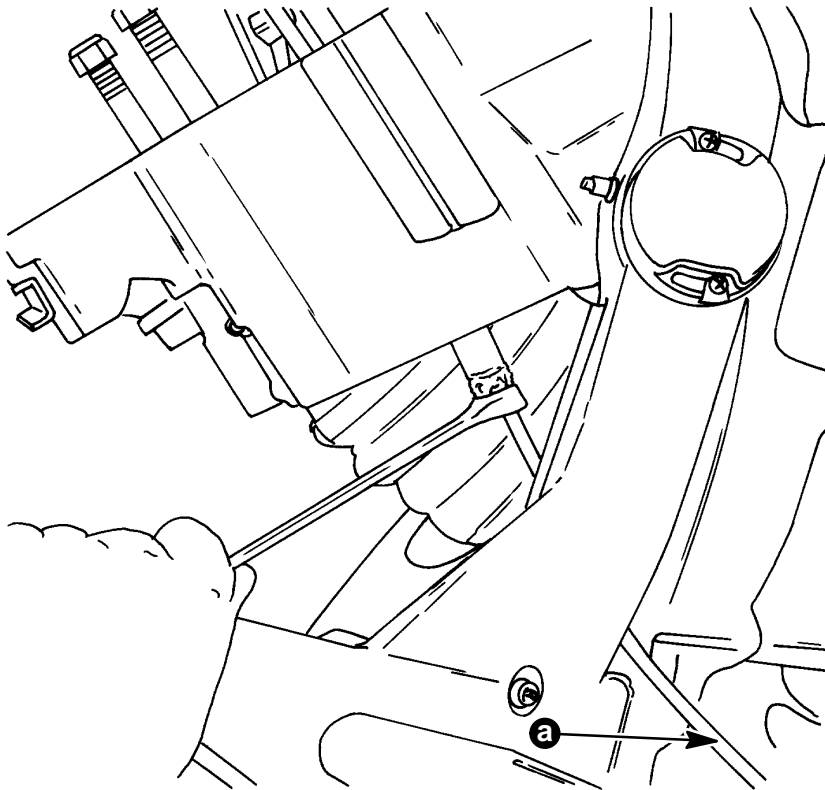

16692

a - Cable Removed From Gimbal Housing
Figure 5. Removing Old Style Cable

Drive Shaft Housing Gears For MerCruiser II and 215E

Mercury Marine will once again stock the drive shaft housing gears for the MerCruiser II and 215E models shown below:

MerCruiser II (Serial No. 2398798 and Above; 1.78:1 Gear Ratio)

Drive and Driven Gear Set - 43-49265A2

Driven Gear - 43-49265

MerCruiser 215E

Gear Assembly (Front) - 43-57501A1

Gear Assembly (Rear) - 43-58854A1

*Driven Gear - 43-54399

**This gear also is used on the MerCruiser 215H models*

MerCruiser “Oildyne” Power Trim Pump Available As a Complete Assembly

The MerCruiser “Oildyne” Power Trim pump (88183A11) used on the current models is now available as a complete assembly for service replacement. The pump includes the floorstand and all the necessary electrical components. This pump can be used to replace any “Oildyne” pump that has the base number of “88183”.