

REMOVAL, INSTALLATION AND ADJUSTMENT

Section 2A - All Models

Table of Contents

**2
A**

Sterndrive Unit Removal	2A-2
Sterndrive Unit Installation	2A-6
Remote Control Shift Cable Adjustment (Drive Unit Installed)	2A-13
Troubleshooting Shift Problems	2A-22
Propeller Installation	2A-23
Transom Assembly Removal	2A-25
Power Steering Models	2A-25
Manual Steering Models	2A-26
Transom Assembly Installation	2A-31
Power Steering Models	2A-36
Manual Steering Models	2A-38

Sterndrive Unit Removal

1. Move remote control shift lever into the FORWARD gear position on standard rotation gear cases, or REVERSE on counter rotation gear cases.
2. Press trailer button on control handle to raise drive unit to trailer position / full-up position.
3. Raise the drive unit to gain access to area between gimbal housing and sterndrive immediately atop the transom end of the anti-ventilation plate.
4. Disconnect speedometer fittings following a. or b. as appropriate:
 - a. Grasp the top half of the plastic fitting, turn counterclockwise and pull up to disengage locking device.

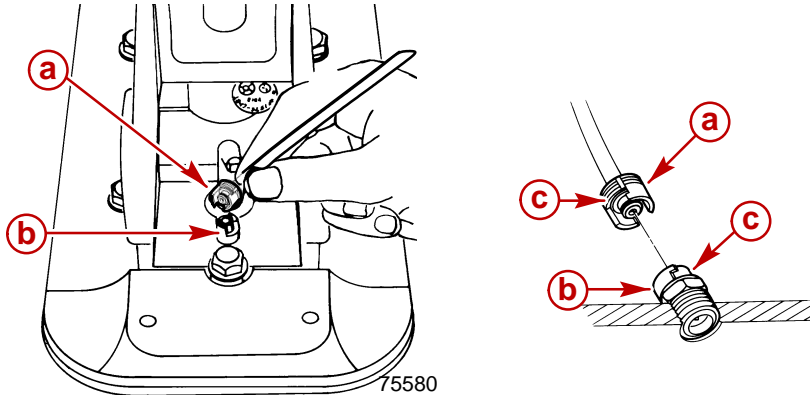

1997-1/2 and Earlier Model Speedometer Connector

- a** - Speedometer Connector, Male End
- b** - Speedometer Connector, Female End
- c** - Alignment Slots

- b. Push in on the release button on the female end of the speedometer connector. Pull to remove.

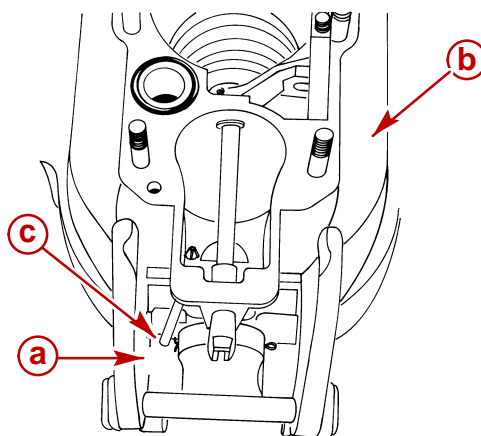
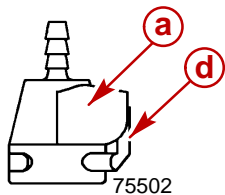

75581

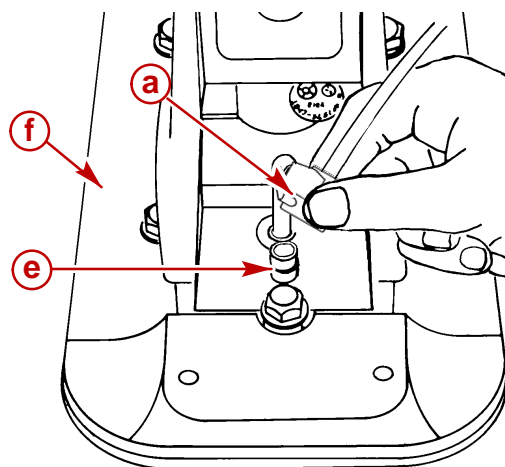

75513

1998 and Later Model Speedometer Connector

- a** - Speedometer Connector, Female End
- b** - Bell Housing
- c** - Sta-Strap
- d** - Release Button
- e** - Speedometer Connector, Male End
- f** - Drive Unit

IMPORTANT: When lifting drive with other than hydraulic system, secure the drive unit with a suitable lifting device so that the drive unit will not fall.

5. Lower drive unit to full IN/DOWN position.

6. Remove power trim cylinders (aft end) from drive unit.

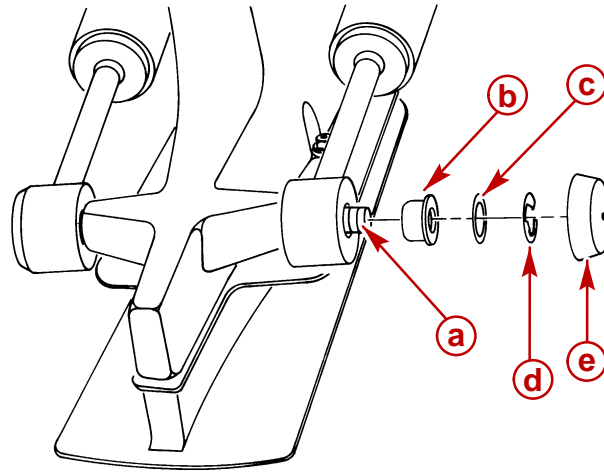

70027

- a** - Aft Anchor Pin
- b** - Bushings (4)
- c** - Flat Washers (2)
- d** - E-ring Clips (2)
- e** - Plastic Caps (2)

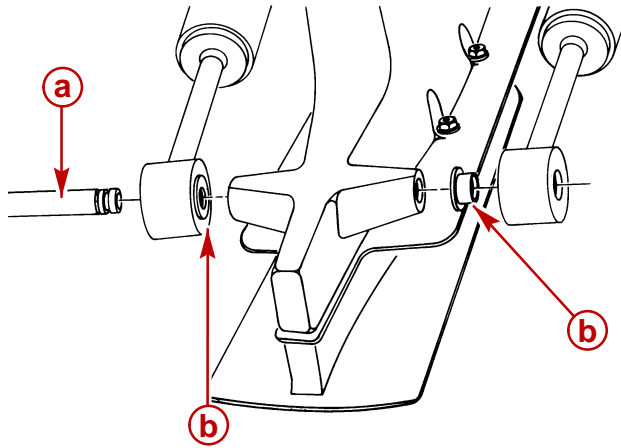

70026

- a** - Aft Anchor Pin
- b** - Bushings

7. Remove the 6 locknuts and 5 washers that hold the drive unit to the transom unit and remove sterndrive unit.

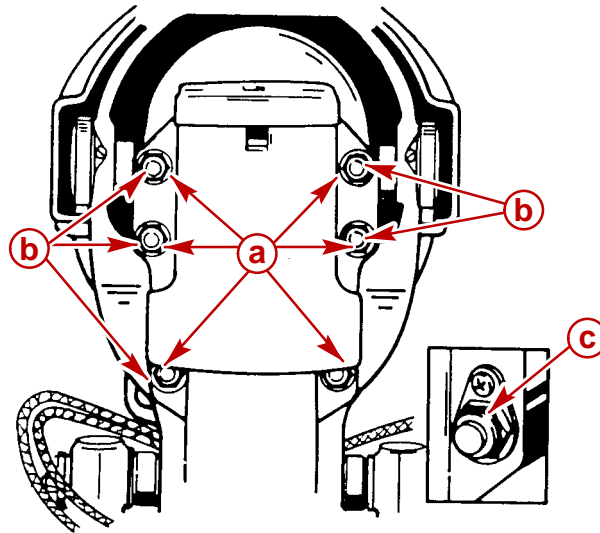

- a** - Locknuts (6)
- b** - Washers (5)
- c** - Ground Plate

22062

8. Remove bell housing gasket.

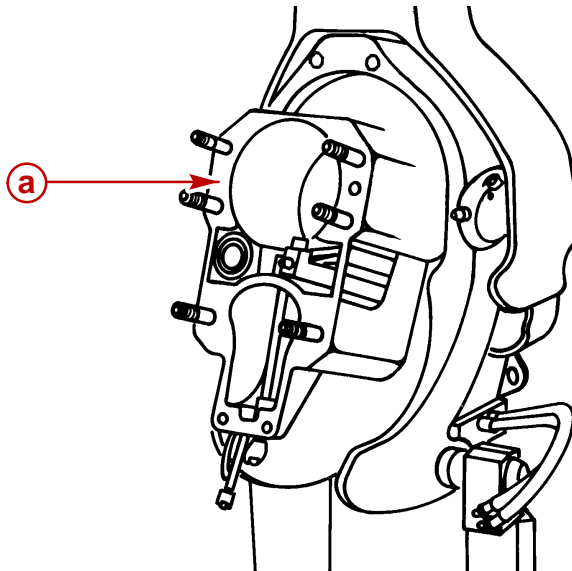

- a** - Bell Housing Gasket

70085

Sterndrive Unit Installation

1. Install and align engine. Refer to appropriate engine service manual.

IMPORTANT: Rubber gasket must be properly positioned and glued in bell housing bore before installing drive unit or water may leak into boat.

2. Ensure that rubber gasket and water passage O-ring are properly positioned in bell housing.
3. Coat entire stud and threads with 2-4-C Marine Lubricant with Teflon.

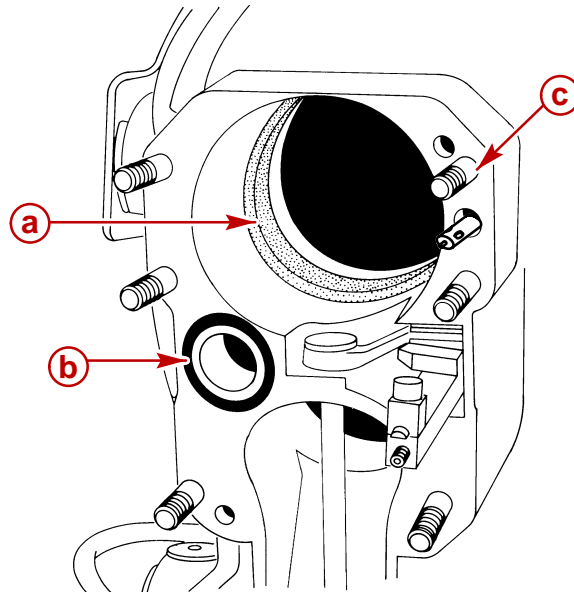

70022

- a** - Rubber Gasket
- b** - Water Passage O-ring
- c** - Studs

4. Coat drive unit pilot, U-joint shaft O-rings and U-joint shaft splines with Engine Coupler Spline Grease.

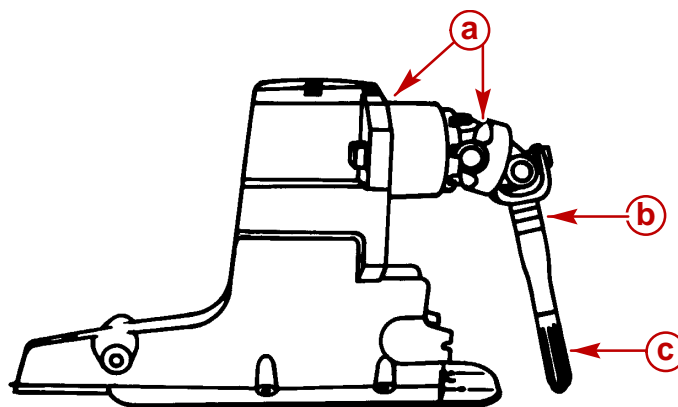

70114

- a** - Drive Unit Pilot
- b** - U-joint Shaft O-rings
- c** - U-joint Shaft Splines

5. Snap the Shift Slide Stabilizer Tool onto stud directly below shift slide and position as shown.

- Position bell housing shift slide so that slot in intermediate shaft coupler is positioned straight fore and aft. Do this by placing remote control shift lever in: **FORWARD gear WOT position for RH drive** or **REVERSE gear position for LH drive unit**.

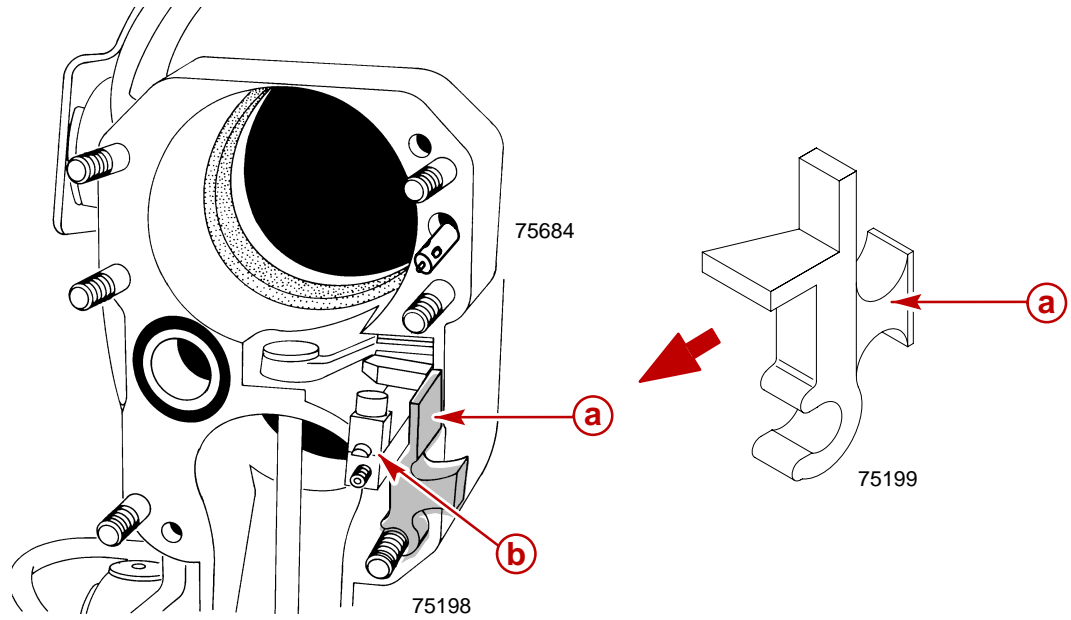

- a** - Shift Shaft Slide Stabilizer Tool
- b** - Shift Slide

IMPORTANT: Shift slide assembly is free to rotate on core wire. Therefore, be careful that shift slide remains in upright position and is properly engaged with shift shaft lever while installing drive unit.

- Position drive unit shift shaft so that is straight forward by turning shift shaft clockwise while simultaneously turning propeller shaft counterclockwise.

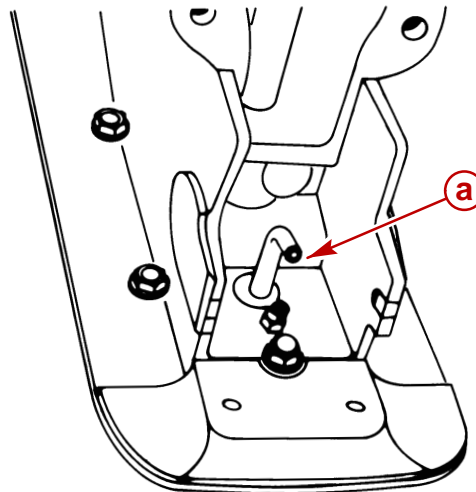

70033

- a** - Drive Unit Shift Shaft Coupler

IMPORTANT: Be sure to install RH or LH drive unit on the appropriate transom assembly when making dual engine installations. The LH rotation drive unit can be identified by the decal on the back side of the upper drive shaft housing, which states: “Alpha One - Counter Rotation” or has an L on the propshaft

8. Place gasket on bell housing.

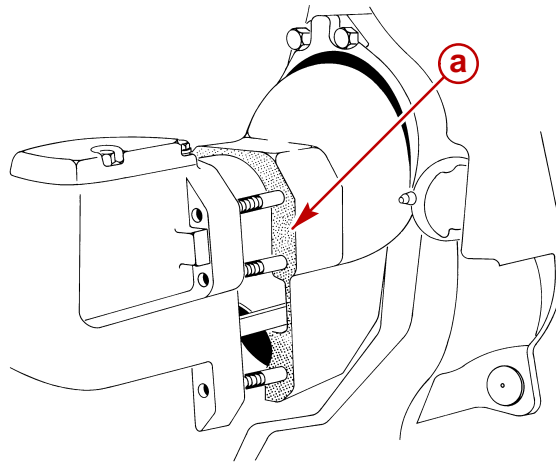

70048

Without Gear Lube Monitor

(Shown Without Shift Slide Stabilizer Tool For Visual Clarity)

a - Gasket

NOTE: If equipped with Gear Lube Monitor **BE SURE** to install the gasket with the hole for oil passage.

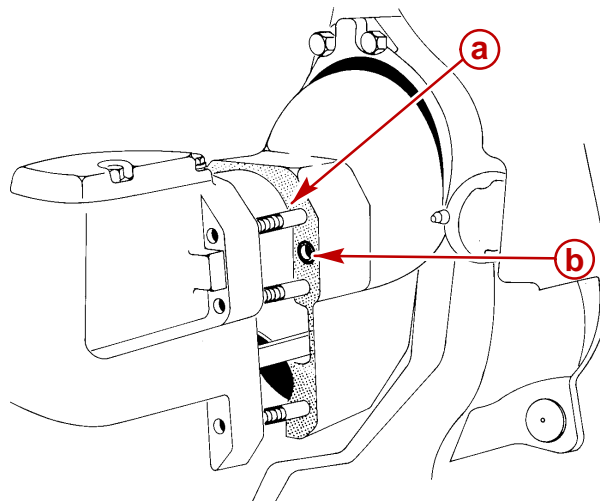

70048

With Gear Lube Monitor

(Shown Without Shift Slide Stabilizer Tool For Visual Clarity)

a - Gasket

b - Oil Passage Hole

9. Install sterndrive unit:
- Position trim cylinder straight back (over top of acceleration plate). Be careful not to scratch acceleration plate or trim cylinders.
 - Guide U-joint shaft through gimbal bearing and into engine coupler while simultaneously guiding shift slide into drive shaft housing. Make sure shift slide remains upright and engaged with bell housing shift shaft lever.
 - After the U-joint shaft has begun to enter the engine coupler, remove the Shift Slide Stabilizer Tool.

- d. Ensure that the stud is thoroughly coated with Quicksilver 2-4-C Marine Lubricant with Teflon.

IMPORTANT: If drive unit will not slide all the way into bell housing, ensure shift shaft couplers are positioned properly and all O-rings are greased. Do not force drive unit into position.

- e. If necessary, rotate propeller shaft counterclockwise slightly to help align U-joint shaft splines with engine coupler splines. Then slide drive unit into bell housing.
10. Secure drive unit to bell housings using fasteners as shown. Torque to 50 lb-ft (68 N•m).

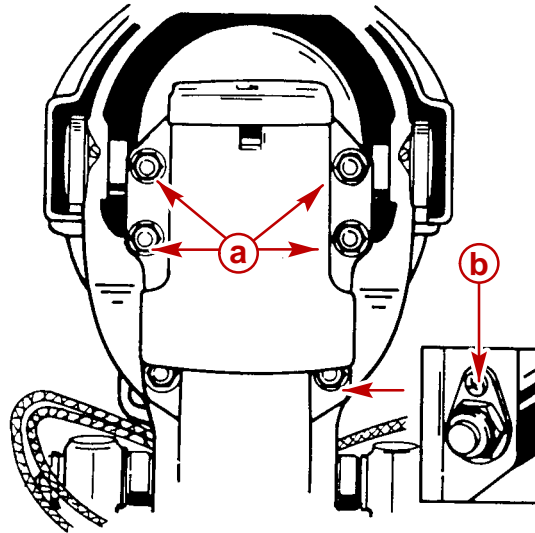

22062

- a** - Locknut and Flat Washers
b - Locknut and Continuity Circuit Washer (No Flat Washer at this Location)

11. Return remote control shift lever to the neutral position.
12. Install trim cylinders on aft end of drive unit with hardware as shown. Coat all components, except plastic caps, with Quicksilver Special Lube 101 upon installation. Push-fit plastic caps onto ends of aft anchor pins.
 - a. Insert one bushing in each inboard hole of both trim cylinders.
 - b. Align the bores of the trim cylinders with that of the drive unit.
 - c. Insert the aft anchor pin through one of the trim cylinders, the drive unit bore and then the other trim cylinder until it protrudes equally on both sides of the unit.

NOTE: Distance between the trim cylinders and the drive unit anchor pin bore is exaggerated for visual clarity.

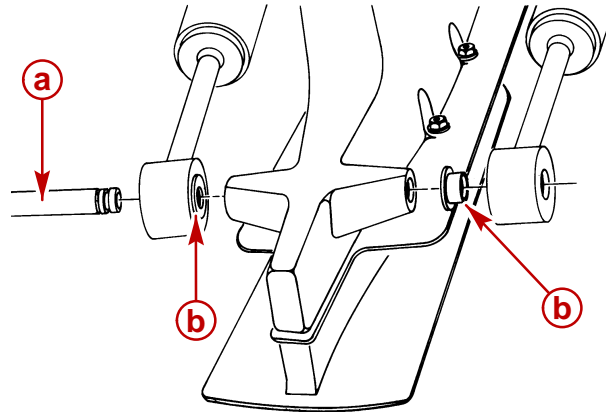

70026

- a** - Aft Anchor Pin
- b** - Bushings

- d. Install the two remaining bushings onto the aft anchor pin ends and fit into bore of trim cylinders.
- e. Install the flat washers.
- f. Install the E-ring clips.

NOTE: The inboard grooves of the aft anchor pin are for E-ring clips, and wider, outboard grooves are for securing plastic caps.

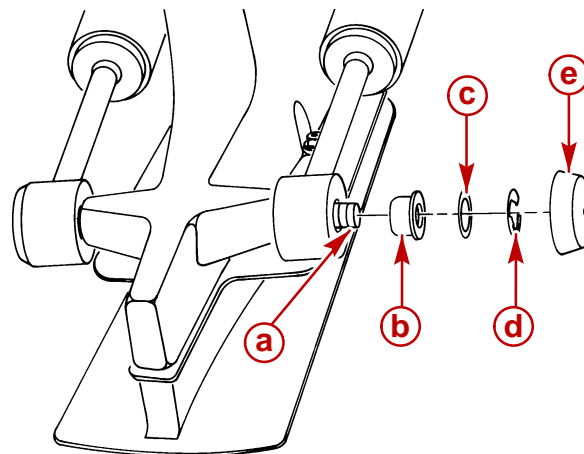

70027

- a** - Aft Anchor Pin
- b** - Bushings
- c** - Flat Washers (2)
- d** - E-ring Clips (2)
- e** - Plastic Caps (2)

13. Raise drive to gain access to area between gimbal housing and sterndrive, immediately atop the transom end of the anti-ventilation plate.
14. Connect speedometer fittings following a. or b. as appropriate:

- a. Align the plastic fittings, push down and turn clockwise to engage locking device.

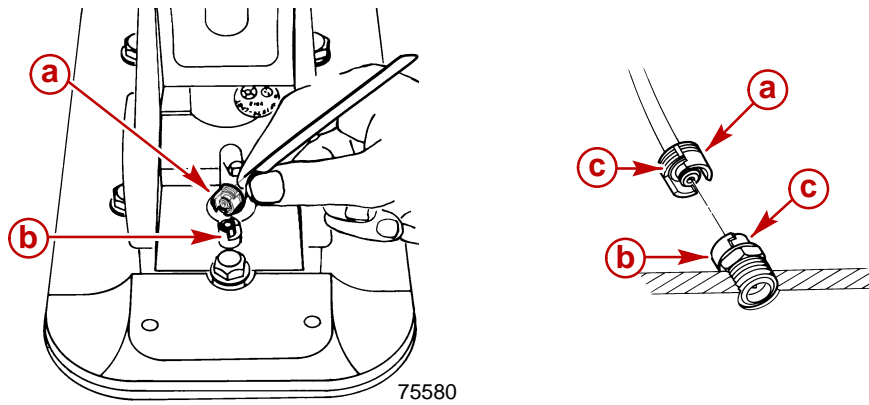

70025

1997-1/2 and Earlier Model Speedometer Connector

- a** - Male End Of Speedometer Fitting
- b** - Female End Of Speedometer Fitting
- c** - Alignment Slots

- b. Push the release button and slide the female portion of the speedometer connector over the male portion.

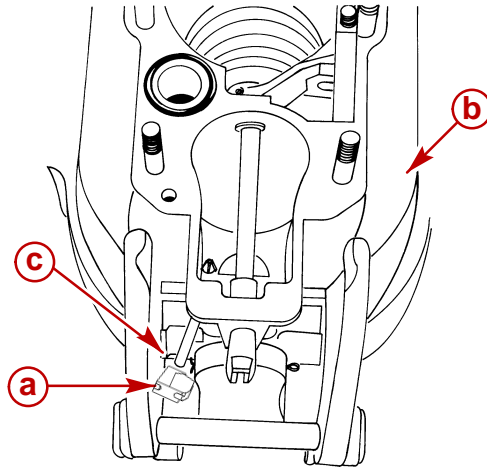

75581

- a** - Speedometer Connector, Female End
b - Bell Housing
c - Sta-Strap

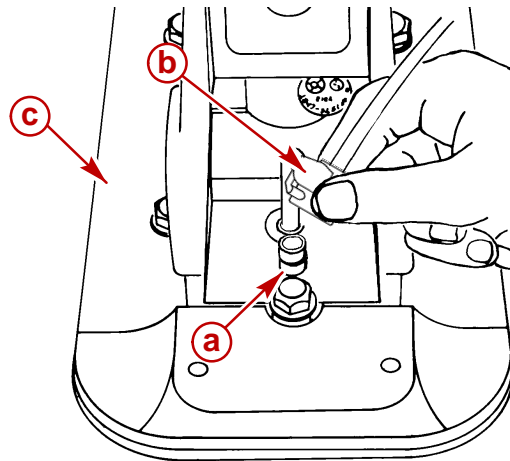

75513

1998 and Later Model Speedometer Connector

- a** - Speedometer Connector, Male End
b - Speedometer Connector, Female End
c - Gear Housing

Remote Control Shift Cable Adjustment (Drive Unit Installed)

NOTE: The illustrations on the following pages show models that have a shift plate that is mounted on the exhaust elbow. The shift mechanism components on the 3.0L model are located on the top of the valve cover or on the starboard harness bracket. The procedure for making the adjustments is the same.

IMPORTANT: Shift cable adjustment for a right hand (RH) rotation drive unit is different than the procedure for adjusting a left hand (LH) rotation drive unit. Be sure to refer to the appropriate procedure when performing the following steps.

IMPORTANT: Drive unit must be installed.

IMPORTANT: DO NOT run engine.

1. Remove remote control shift cable and shift assist assembly (if installed).

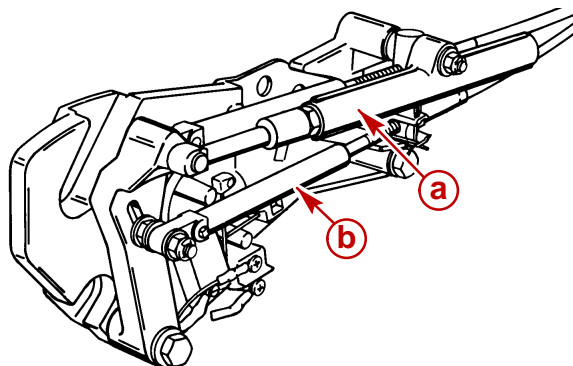

50308

With Shift Assist Assembly

- a** - Shift Assist Assembly
- b** - Remote Control Shift Cable

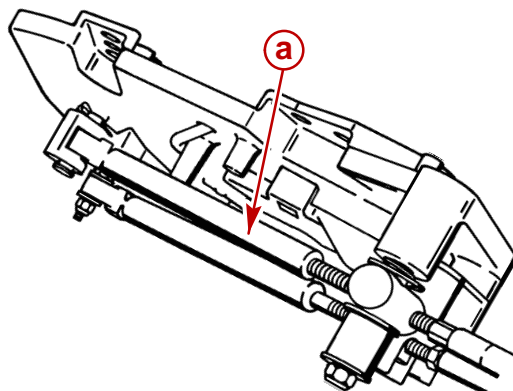

50310

Without Shift Assist Assembly

- a** - Remote Control Shift Cable

2. Ensure shift lever adjustable stud is located in the slot at the end closest to the shift lever pivot point. If necessary, loosen stud and align stud in the slot, then retighten stud.

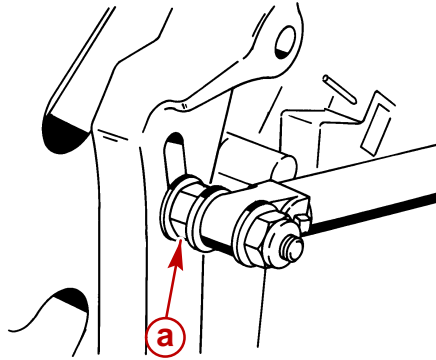

50309

a - Adjustable Stud

3. Shift remote control as stated in a. or b.:
 - a. **Right Hand (RH) Rotation Drive Unit** - forward gear, past detent, into wide-open-throttle position.
 - b. **Left Hand (LH) Rotation Drive Unit** - reverse gear, past detent, into wide-open-throttle position.

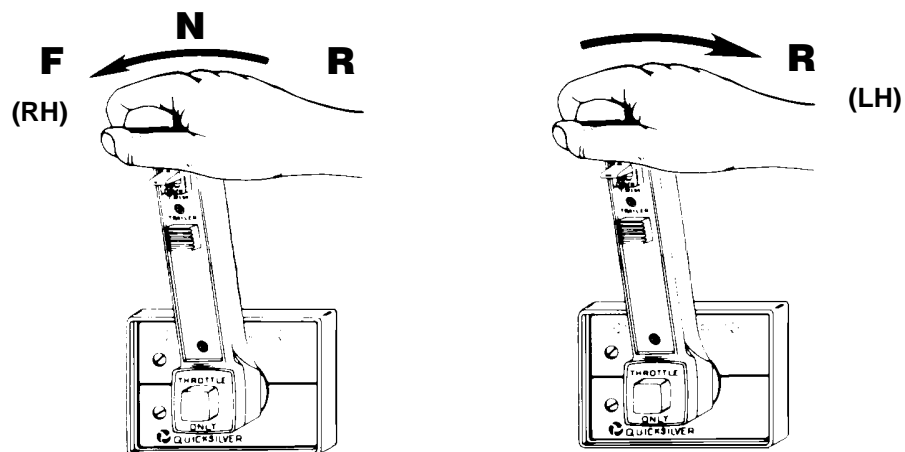

4. Place drive unit into gear by pushing in on drive unit shift cable, while simultaneously rotating propeller shaft counterclockwise until shaft stops, to ensure full clutch engagement. Maintain a light pressure on the drive unit shift cable to hold it at the end of its travel (this removes all slack from the cable).

IMPORTANT: Do not use excessive force when holding pressure on the drive unit shift cable. Excessive force would be indicated by movement of the V-notch of the actuator lever assembly.

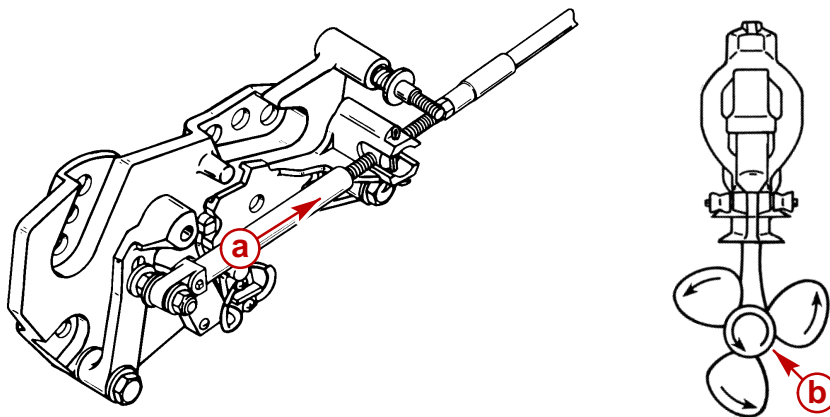

22266

- a** - Drive Unit Shift Cable - Push In
- b** - Propeller Shaft - Rotate Counterclockwise

5. Lightly pull on remote control shift cable end guide (to remove slack from remote control and cable) and adjust brass barrel as necessary to align attaching points with shift lever clevis pin hole and stud. Be sure to maintain light pressure on drive unit shift cable.

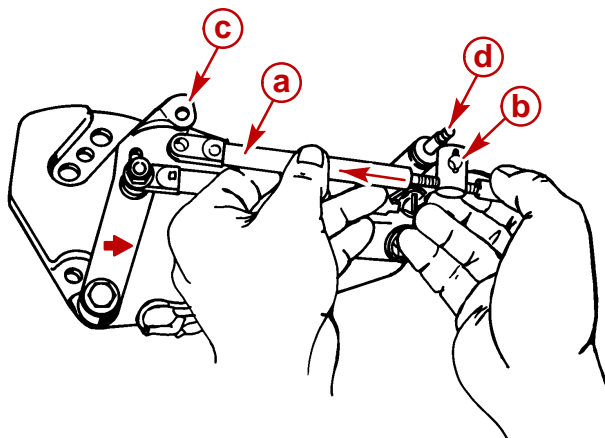

50309

- a** - End Guide
- b** - Brass Barrel
- c** - Shift Lever Clevis Pin Hole
- d** - Stud

6. After cable has been aligned, turn brass barrel 4 turns **away** from cable end guide.

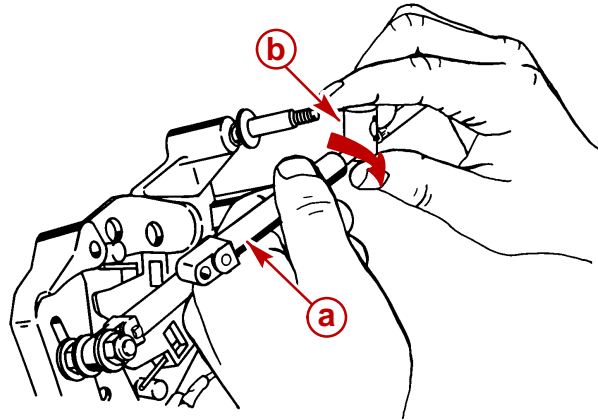

50308

- e** - End Guide
- f** - Brass Barrel

7. Temporarily install remote control shift cable on stud and install clevis pin.

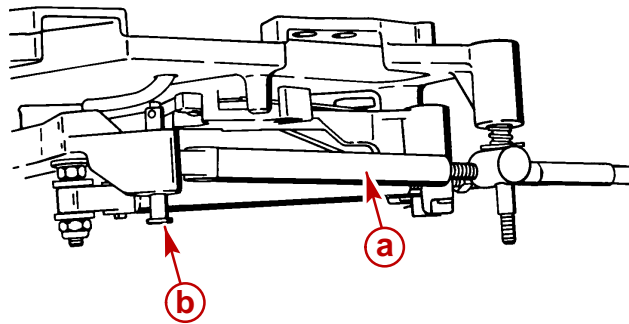

50308

- a** - Remote Control Shift Cable
- b** - Clevis Pin

8. Shift remote control as stated in a. or b. :
 - a. **Right Hand (RH) Rotation Drive Unit** - reverse gear, past detent, into wide-open-throttle position.
 - b. **Left Hand (LH) Rotation Drive Unit** - forward gear, past detent, into wide-open-throttle position.

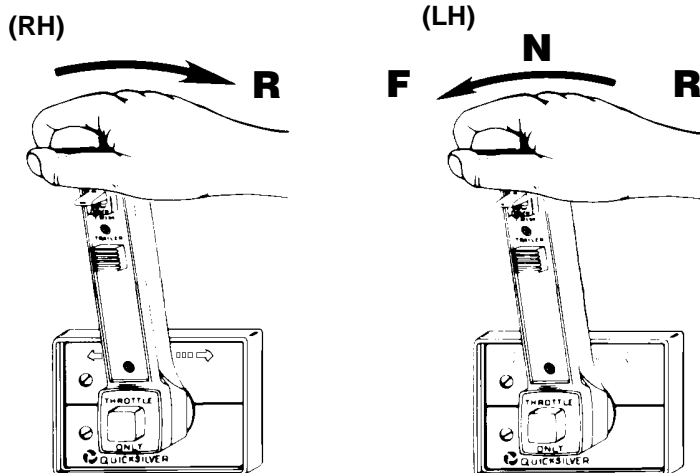

9. Simultaneously rotate propeller shaft clockwise until shaft stops to ensure full clutch engagement.

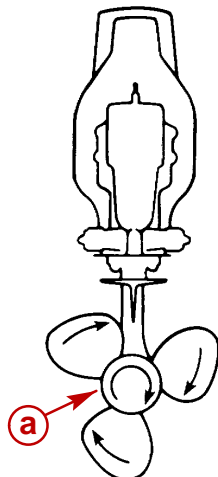

22267

a - Propeller Shaft - Rotate Clockwise

10. Perform a. or b. as appropriate:

- a. **On Models with Earlier Type Switch:** check shift cutout switch lever position. Roller must be centered.

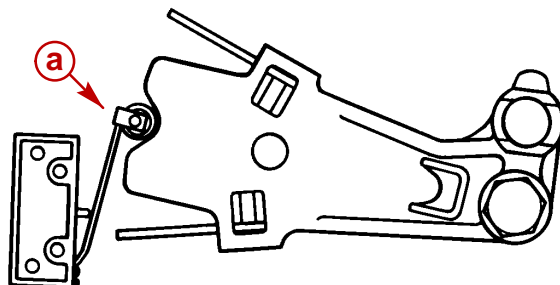

22058

a - Shift Cutout Switch Roller

- b. **On Models with Later Type Switch:** check shift cutout switch plunger position. Pin must be centered.

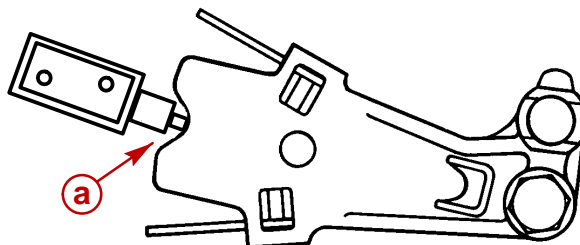

75128

a - Shift Cutout Switch Plunger

11. If roller or plunger pin is not centered:

- a. Ensure adjustable stud is at bottom of slot in shift lever.
- b. Check remote control for proper shift cable output [3 in. (76 mm) \pm 1/8 in. (3 mm)].
- c. If a and b are correct, ensure drive unit shift cable is not crushed or kinked. (If drive unit shift cable is binding, the shift cutout switch roller or plunger pin will move off center when shifting "into" and "out of" forward **and** reverse).

NOTE: *If shift cable was damaged during installation, install new shift cable assembly, then repeat shift cable adjustment procedure.*

⚠ CAUTION

Improper installation of the shift assist assembly could result in damage or malfunction to the shift control box.

For Commander 3000 Controls, if shift assist assembly attaching points do not align, verify controller is in the neutral position. Remove the shift cable and reposition the adjustment barrel as required to allow the shift assembly to be installed with no effort.

For ALL other controls, if shift assist assembly attaching points do not align, push in or pull out on end of shift assist assembly to install. Do not attempt to readjust shift cable.

12. After remote control shift cable has been properly adjusted, reinstall cable and shift assist assembly (if applicable) and secure with hardware. Tighten locknut completely then back off 1/2 turn.

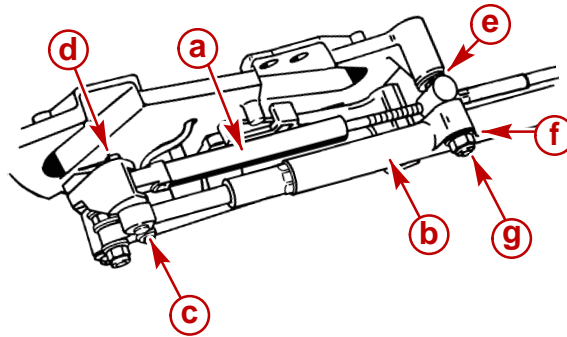

50308

With Shift Assist Assembly

- a** - Remote Control Shift Cable
- b** - Shift Assist Assembly
- c** - Clevis Pin
- d** - Cotter Pin
- e** - Large I.D. Washer
- f** - Small I.D. Washer
- g** - Locknut

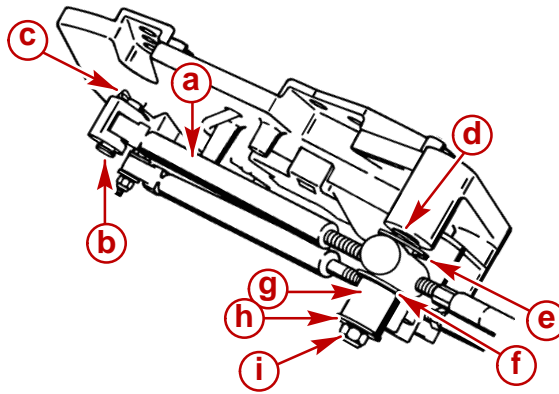

50310

Without Shift Assist Assembly

- a** - Remote Control Shift Cable
- b** - Clevis Pin
- c** - Cotter Pin
- d** - Spring
- e** - Washer
- f** - Washer
- g** - Spacer
- h** - Washer
- i** - Locknut

IMPORTANT: If an extra long remote control shift cable is used, or if there are a large number of bends in remote control shift cable, or remote control has inadequate output travel, an additional adjustment may be necessary. Refer to step 13 or 14 as applicable.

13. Remote Control with Single Lever Shift/Throttle Control:

- a. RIGHT HAND (RH) propeller rotation drive unit** - Shift remote control into reverse gear, wide-open-throttle position while simultaneously rotating propeller shaft clockwise. Clutch should engage and cause propeller shaft to lock. If clutch does not engage, loosen adjustable stud on shift lever and move it upward in slot until clutch engages with reverse gear. Retighten stud. Shift remote control several times and stop in reverse to recheck shift cutout switch position. Roller or pin must be centered.
- b. LEFT HAND (LH) propeller rotation drive unit** - Shift remote control into forward gear, wide-open-throttle position while simultaneously rotating propeller shaft clockwise. Clutch should engage and cause propeller shaft to lock. If clutch does not engage, loosen adjustable stud on shift lever and move it upward in slot until clutch engages with forward gear. Retighten stud. Shift remote control several times and stop in forward to recheck shift cutout switch position. Roller or pin must be centered.

14. Two Lever Remote Control with Separate Shift and Throttle Levers:

- a. RIGHT HAND (RH) propeller rotation drive unit** - While turning propeller shaft clockwise, move remote control shift handle into full reverse position. Clutch should engage before shift lever comes to a stop. If clutch does not engage, loosen adjustable stud on shift lever and move it upward in slot until clutch engages with reverse gear. Retighten stud. Shift remote control several times and stop in reverse to recheck shift cutout switch position. Roller or pin must be centered.
- b. LEFT HAND (LH) propeller rotation drive unit** - While turning propeller shaft clockwise, move remote control shift handle into full forward position. Clutch should

engage before shift lever comes to a stop. If clutch does not engage, loosen adjustable stud on shift lever and move it upward in slot until clutch engages with forward gear. Retighten stud. Shift remote control several times and stop in forward to re-check shift cutout switch position. Roller or pin must be centered.

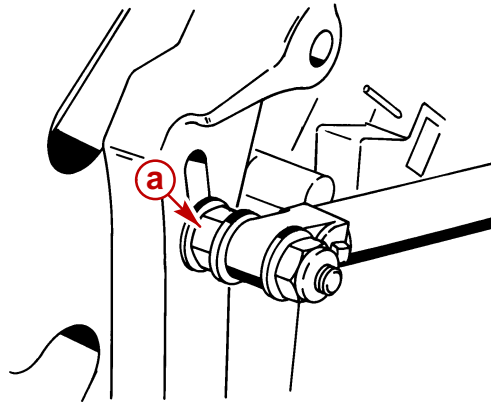

50309

a - Adjustable Stud

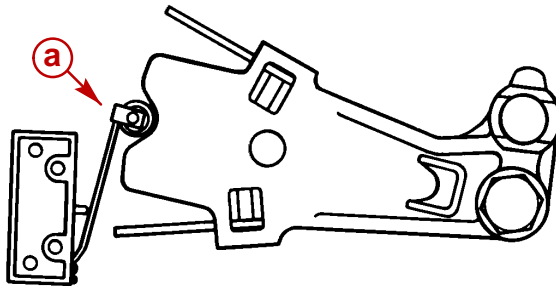

22058

a - Shift Cutout Switch Roller

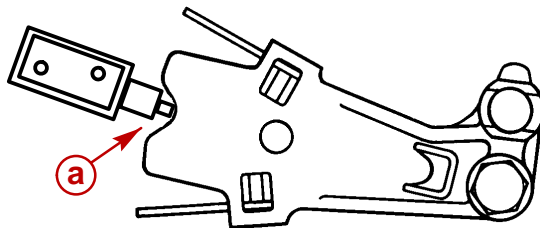

75128

a - Shift Cutout Switch Plunger

Troubleshooting Shift Problems

NOTE: The following information is provide to assist an installer in troubleshooting if hard shifting or chocking/racheting is encountered when shifting into FORWARD gear.

1. When installing the control box in the side panel of the boat, make sure that the cables have enough clearance to operate. This is necessary because the cables move up and down when the shift handle is moved. If the control box is mounted too far back towards any fiberglass structure, the cables will be interfered with, this will cause very hard shifting.

NOTE: The control box housing can be rotated in 30° increments to improve cable routing.

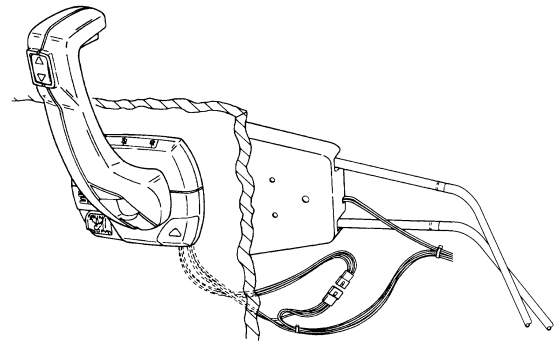
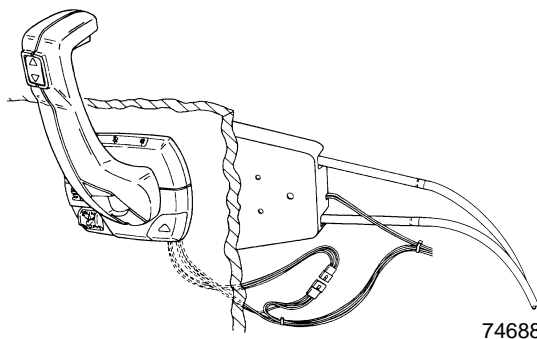

Proper Cable Bend

Improper Cable Bend

2. Ensure that when the shift cable from the control box is led through the side gullet of the hull, it does not have any extremely sharp bends in it as this will cause the stiff shifting.
3. Before installing the shift cable into the control box, extend the stainless rod eye end of the cable and grease it with 2-4-C Marine Lubricant with Teflon. Move it back and forth to allow even distribution of the grease.

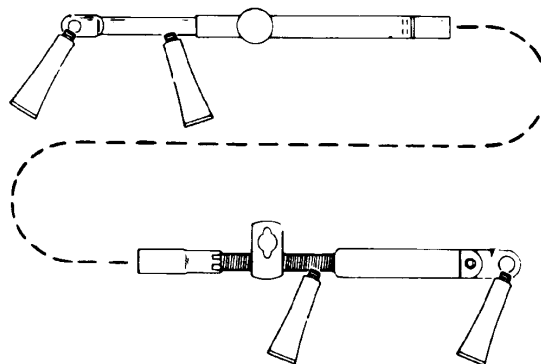

22005

4. Do not strap or clamp the control cables to any other cables or rigid structure within **3 ft. (914 mm)** of the control box.
5. Be sure the cable is not permanently kinked.
6. Make sure there is proper clearance for cable movement when the control box is installed in the side panel. The cables must have room to move up and down when the control handle is shifted into either FORWARD or REVERSE.
7. Ensure that the engine was not set down on the intermediate shift cable during installation, as this will crush the inner cable tubing and cause improper and / or stiff shifting.

8. DO NOT fasten the shift cable with straps or clamps to any other cable within **5 ft. (1524 mm)** of the shift plate.
9. DO NOT fasten the shift cable to the transom with any type of plastic clips or fasteners within **5 ft. (1524 mm)** of the shift plate.
10. DO NOT overtighten the throttle or shift cable attaching nuts at the engine end. Barrel and cable end must be free to rotate on the mounting stud.
11. Check the intermediate shift cable routing from the transom assembly to the shift plate as follows:
 - a. The cable should come through the transom, above the exhaust pipe and make a turn towards the starboard side of the boat between the exhaust pipe and the engine flywheel housing.
 - b. The cable should then be routed under the starboard rear engine mount, and turn towards the transom.
 - c. Then go up behind the power steering valve and loop over to the shift plate on the engine, where it is connected to the anchor points on the shift plate.

Following this routing will prevent the engine coupler from damaging the cable.

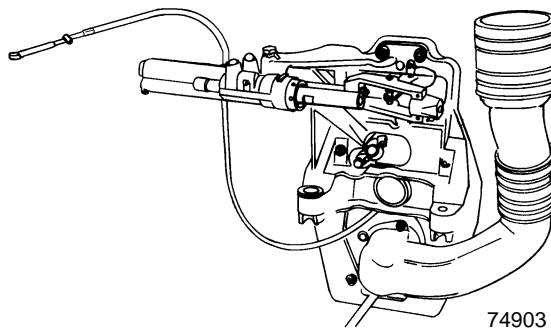

74903

4 Cylinder Inline Model

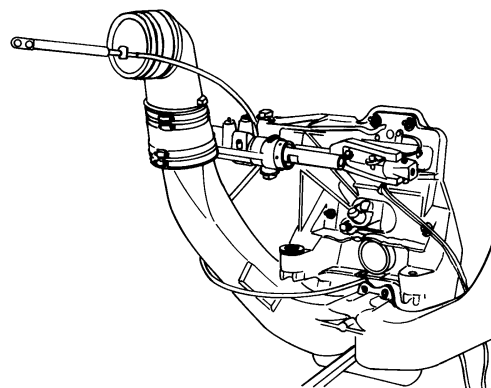

74901

V6 and V8 Models

Propeller Installation

⚠ WARNING

Be sure that remote control is in the neutral position and ignition key is removed from switch.

⚠ WARNING

Place a block of wood between the antiventilation plate to protect hands from propeller blades and to prevent propeller from turning.

1. To aid in future propeller removal, liberally coat the propeller shaft splines with one of the following lubricants; then, install propeller.
 - Special Lubricant 101
 - 2-4-C Marine Lubricant with Teflon
 - Perfect Seal

IMPORTANT: Installation is correct when at least 2 threads of propeller shaft are exposed through propeller nut.

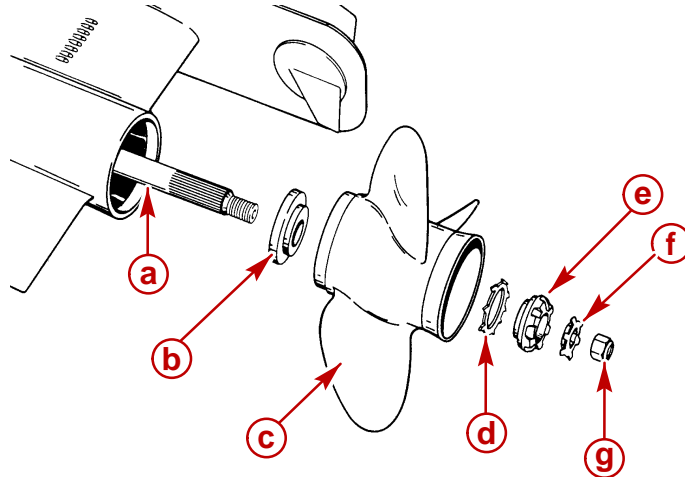

22074

Propeller Without Flo-Torq II Drive Hub

- a** - Propeller Shaft
- b** - Forward Thrust Hub
- c** - Propeller
- d** - Continuity Washer
- e** - Spline Washer
- f** - Tab Washer
- g** - Propeller Nut

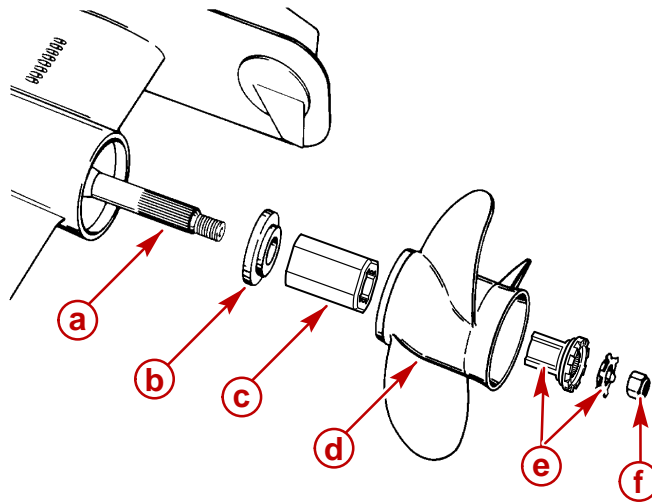

70134

Propeller With Flo-Torq II Drive Hub

- a** - Propeller Shaft
- b** - Forward Thrust Hub
- c** - Flo Torq II Drive Hub
- d** - Propeller
- e** - Drive Sleeve Adapter and Locking Tab Washer
- f** - Propeller Nut

2. Torque propeller nut until 55 lb-ft (75 N•m) is obtained and continue until 3 tabs on tab washer align with grooves on drive sleeve.
3. Bend tabs into drive sleeve.

Transom Assembly Removal

Power Steering Models

NOTE: If Tie Bars need to be removed or serviced see section 6A or 6B.

1. Remove the power steering assembly..
 - a. Disconnect clevis from steering lever.
 - b. Disconnect steering cable from clevis.

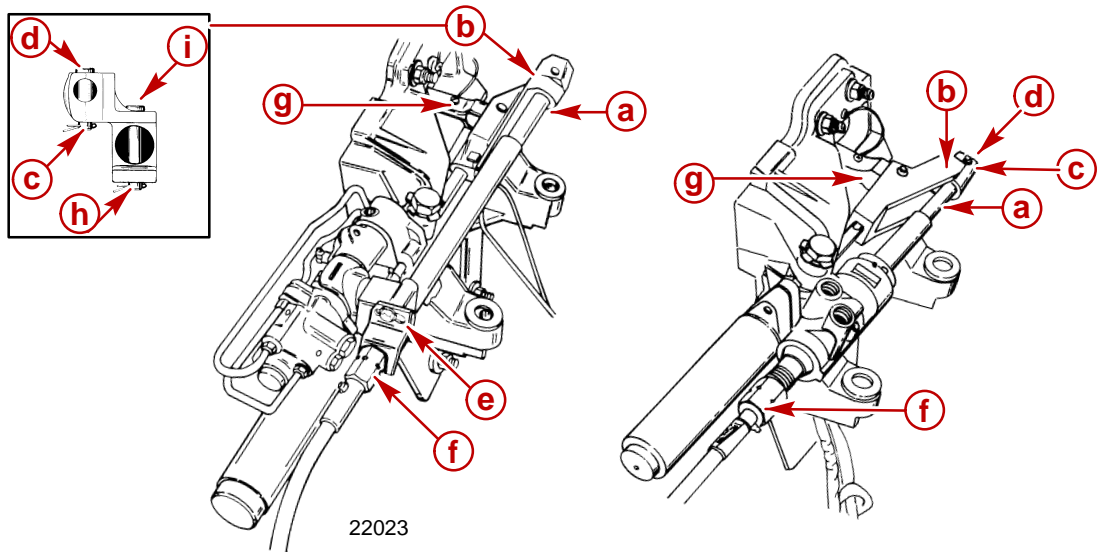

Earlier Model Control Valve **Later Model Control Valve**

- a** - Cable End
- b** - Clevis
- c** - Cotter Pin
- d** - Clevis Pin
- e** - Locking Plate
- f** - Cable Retaining Nut
- g** - Steering Lever
- h** - Cotter Pin
- i** - Clevis Pin

- c. Bend tabs away from pivot bolts then loosen bolts and remove power steering unit.

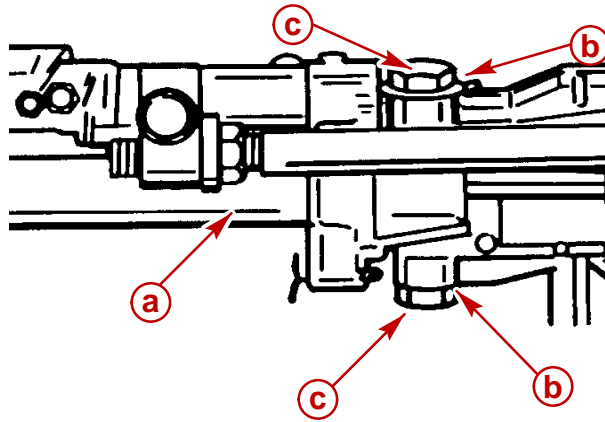

23256

- a** - Power Steering Unit
- b** - Tab Washer
- c** - Pivot Bolt

Manual Steering Models

1. Remove the manual steering assembly.
 - a. Disconnect steering cable or clevis from steering lever.

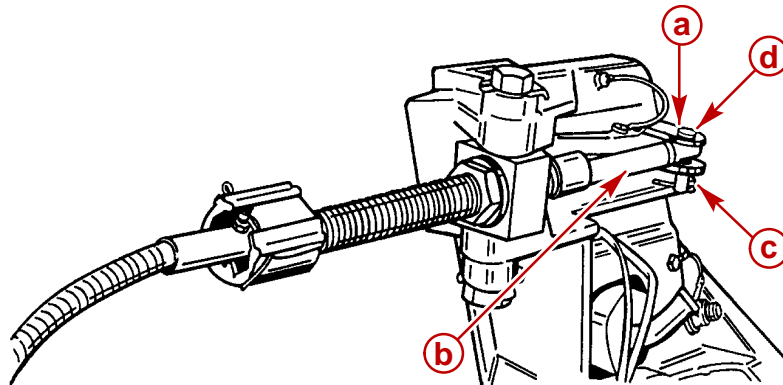

22055

- a** - Steering Lever
- b** - Steering Cable
- c** - Cotter Pin
- d** - Clevis Pin

- b. Bend tabs away from pivot bolts. Loosen bolts and remove manual steering swivel ring.

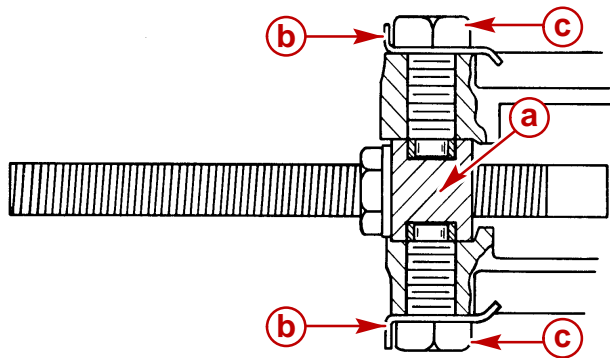

22945

- a - Swivel Ring
- b - Tab Washer
- c - Pivot Bolt

- 2. Disconnect gear lube monitor hose, if equipped. Plug hose and cap fitting.

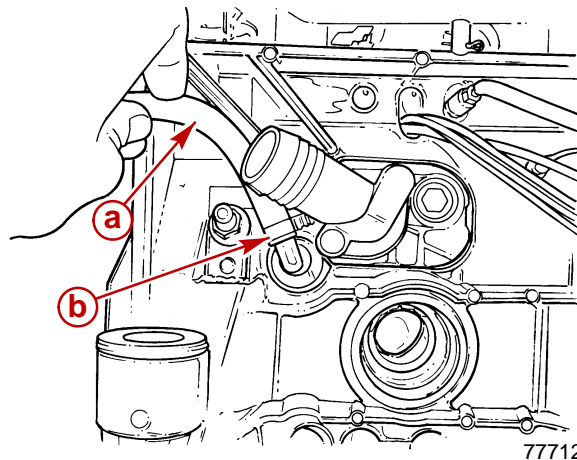
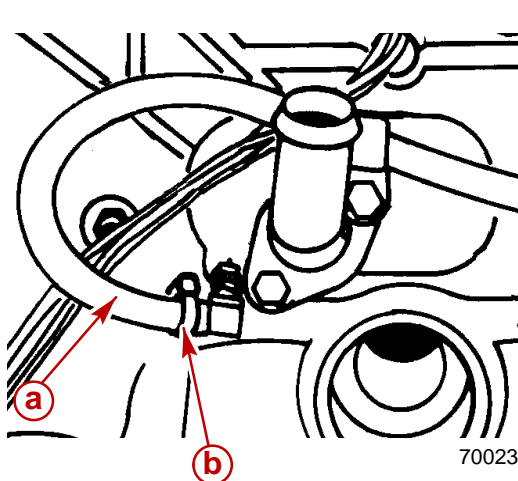

..... Earlier Style Later Style

- a - Hose
- b - Hose Clamp

- 3. Disconnect speedometer hose, if equipped.

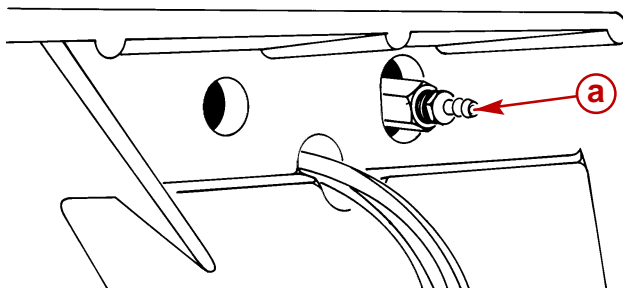

70015

- a - Speedometer Fitting

- 4. Disconnect MerCathode wires from control unit on engine, if equipped.

5. Disconnect trim limit switch wires at trim pump and trim position sender wires at engine.
6. For engine removal, refer to appropriate engine service manual.
7. Disconnect power trim hydraulic hoses from trim pump. Cap hoses and plug pump fitting holes.

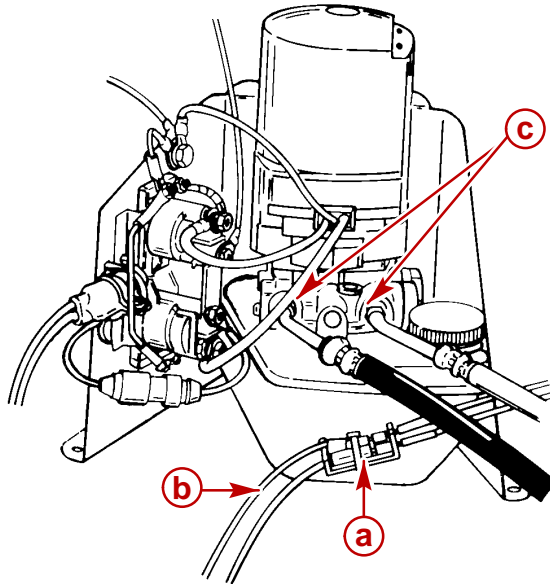

- a** - Sta-Strap
- b** - Trim Limit Switch Wires
- c** - Hydraulic Hoses

22031

8. If installed, remove exhaust pipe.

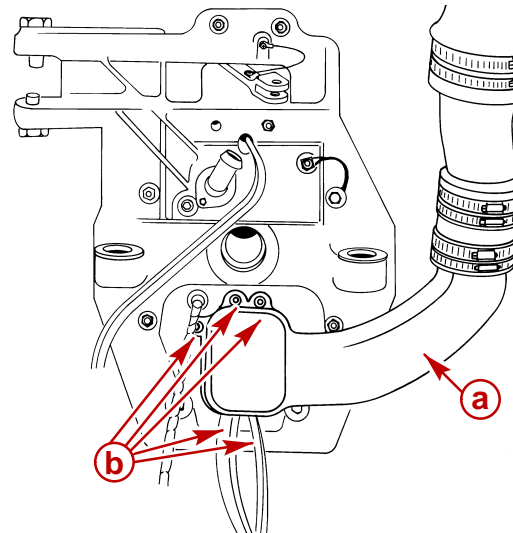

70068

In-line 4 Cylinder Models

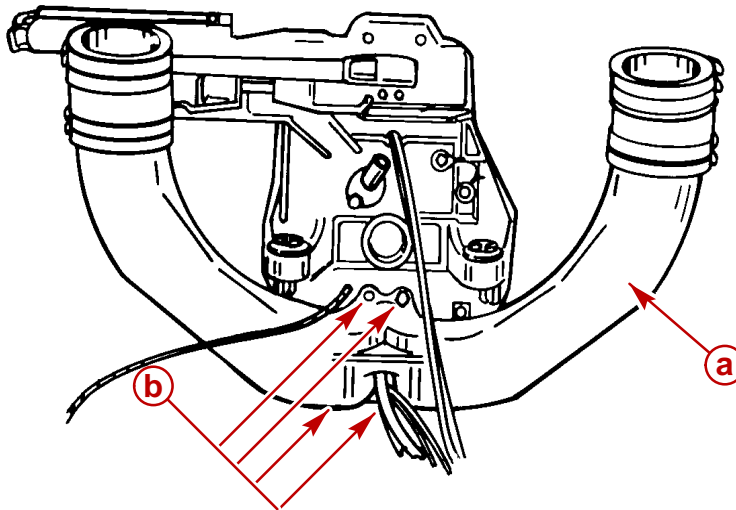

22057

V6/V8 Models

- a** - Exhaust Pipe
- b** - Screws

9. Remove ground wire from steering lever.

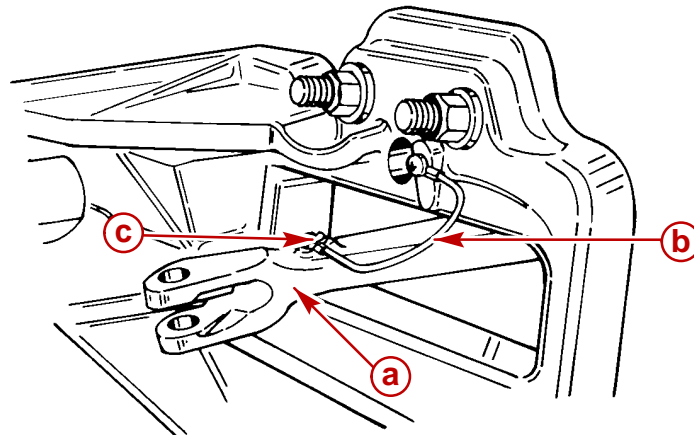

22028

- a** - Steering Lever
b - Ground Wire
c - Screws

⚠ CAUTION

Transom gimbal housing (on outside of boat must be secured prior to the next step to prevent dropping.

10. Remove all nuts, bolts and washers (items "a" and "h" in diagram) and separate inner transom plate from transom gimbal housing.
 11. Remove transom gimbal housing from transom of boat.

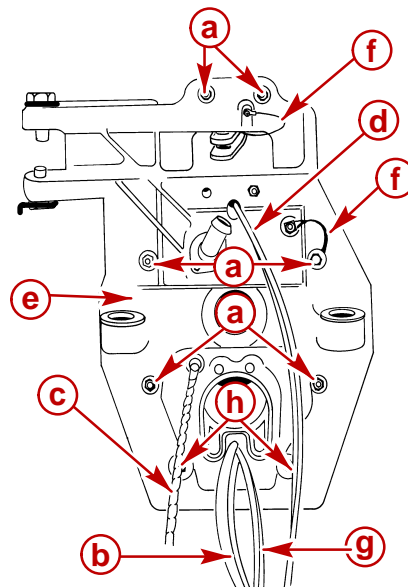

70012

- a** - Flat Washers and Locknuts
b - Hydraulic Hoses
c - Drive Unit Shift Cable
d - Trim Limit And Trim Position Sender Wires
e - Inner Transom Plate
f - Ground Wire (Continuity Circuit)
g - MerCathode Wires (If Equipped)
h - Long Screws, Lock Washers And Square Flat Washers (Later Models - Studs With Locknuts And Flat Washers)

Transom Assembly Installation

⚠ CAUTION

On earlier style transom assembly with carriage bolts at the bottom, rubber seal **MUST BE** installed on the bolts or water will leak into boat.

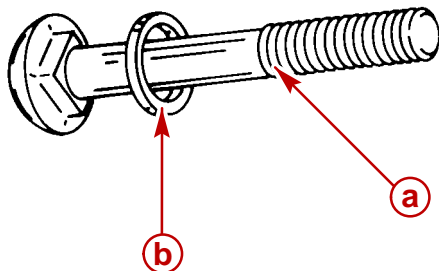

22028

- a - Carriage Bolt
- b - Rubber Seal

⚠ CAUTION

Steering lever ground wire **MUST BE** positioned as shown or wire may fatigue.

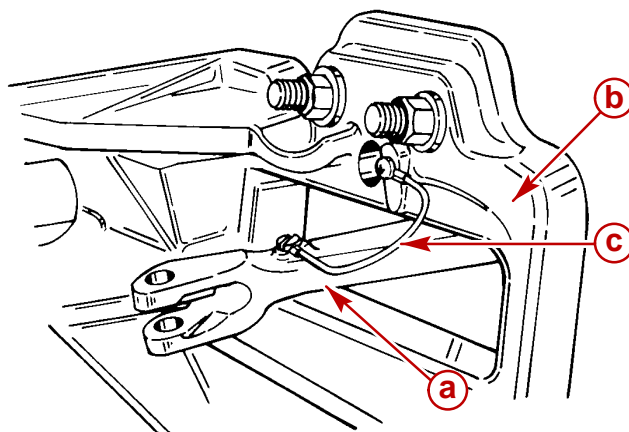

22028

- a - Steering Lever
- b - Inner Transom Plate
- c - Ground Wire

IMPORTANT: Be sure to pull all wires and cables completely through inner transom plate and ensure wires are not pinched when installing gimbal housing to transom.

IMPORTANT: Torque bolts and nuts evenly (starting from center and working out) to 22.5 lb-ft (30.5 N•m).

1. Install transom assembly. Tighten attaching bolts and nuts evenly (starting from center and working out). Torque to 22.5 lb-ft (30.5 N•m).

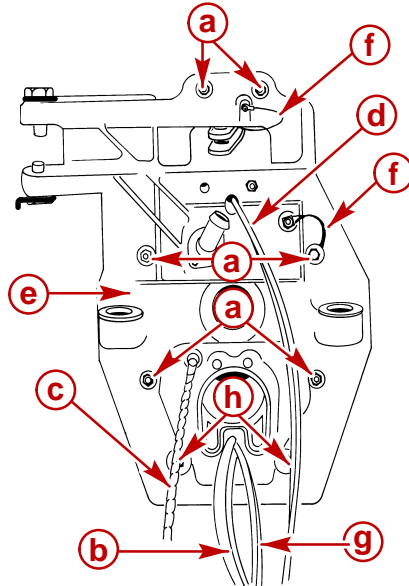

70012

- a** - Flat Washers and Locknuts
- b** - Hydraulic Hoses
- c** - Drive Unit Shift Cable
- d** - Trim Limit And Trim Position Sender Wires
- e** - Inner Transom Plate
- f** - Ground Wire (Continuity Circuit)
- g** - MerCathode Wires (If Equipped)
- h** - Carriage Bolts With Flat Washers And Locknuts (Later Models - Studs, Flat Washers And Locknuts)

2. If equipped, connect gear lube monitor hose.

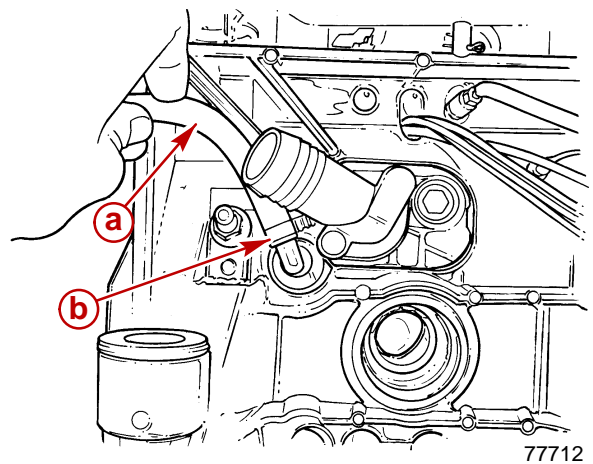
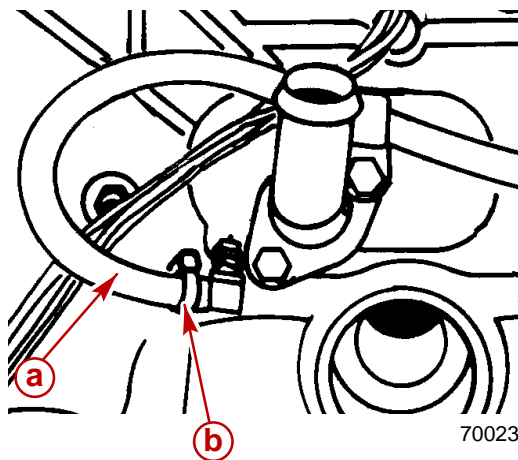

..... **Earlier Style** **Later Style**

- a** - Hose
- b** - Hose Clamp

3. If equipped, connect hose from the speedometer to the barb fitting and secure with cable tie.

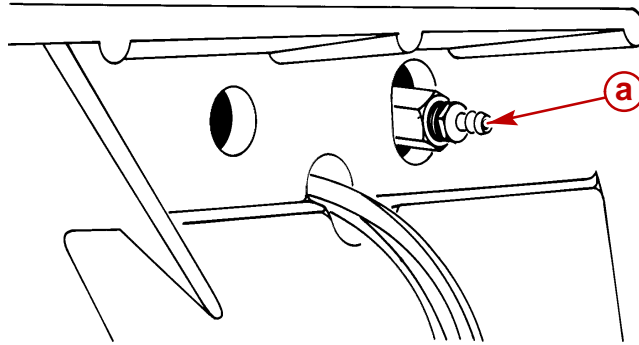

70015

a - Barb Fitting

IMPORTANT: Exhaust pipe and gimbal housing mating surfaces must be clean and free of nicks and scratches or exhaust may leak into boat.

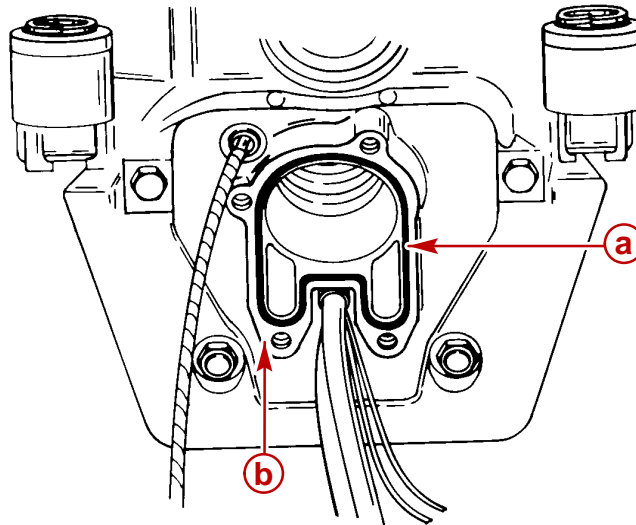

22057

a - O-ring Seal
b - Mating Surface

4. If equipped, glue O-ring seal to gimbal housing.

5. Install exhaust pipe or block off plate on gimbal housing. Torque screws to 22.5 lb-ft (30.5 Nm).

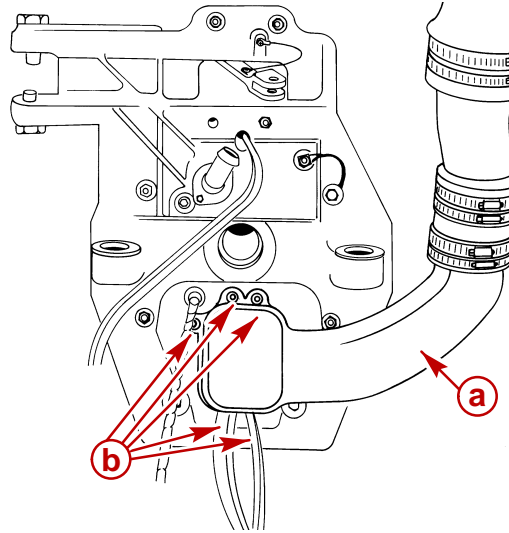

70068

In-line 4 Cylinder Models

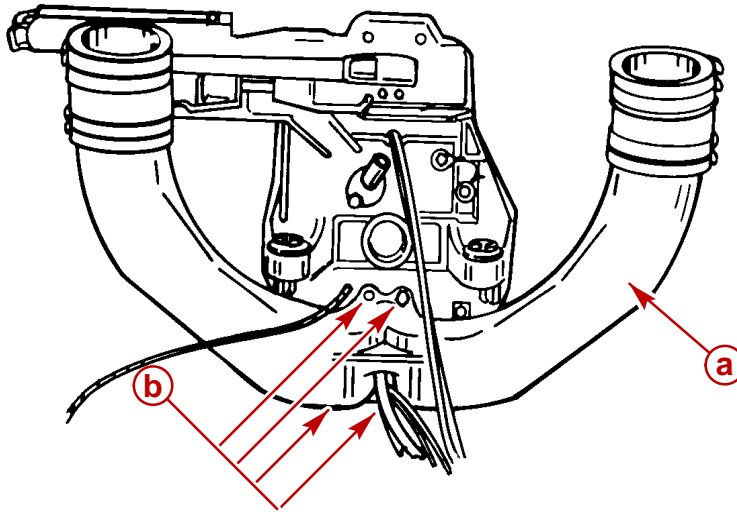

22057

V6/V8 Models

- a** - Exhaust Pipe
- b** - Screws

- If using through-transom exhaust, install block off plate and O-ring seal. Torque to 22.5 lb-ft (30.5 Nm)

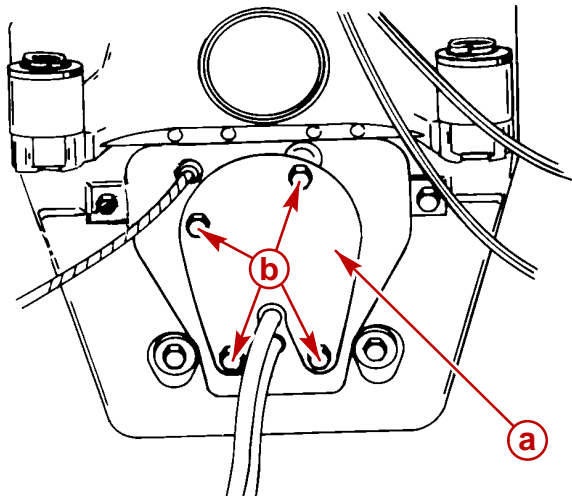

22057

Models with Through The Transom Exhaust

- a** - Block Off Plate
- b** - Screws

⚠ CAUTION

DO NOT cross thread or overtighten hose fittings when making hydraulic hose connections to power trim pumps.

IMPORTANT: Make hydraulic hose connections as quickly as possible to prevent oil from leaking out of trim system.

- Connect power trim pump hydraulic hoses. Torque to 125 lb-in. (14.1 Nm).

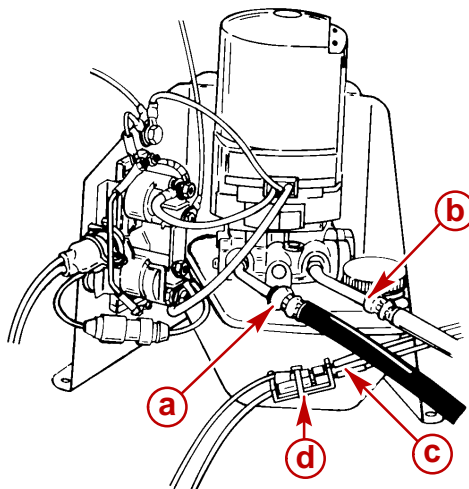

22031

- a** - Black Hose (Up Hose)
- b** - Gray Hose (Down Hose)
- c** - Trim Limit Switch Wires
- d** - Wire Retainer and Sta-Strap

- Connect trim limit switch wires.

Power Steering Models

1. Install power steering assembly on inner transom plate.
 - a. Lubricate power steering unit bushings with Special Lubricant 101.

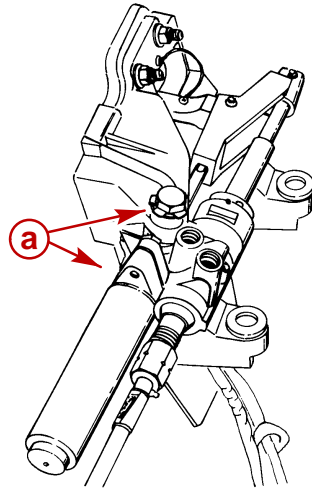

71901

a - Power Steering Unit Bushings

- b. Slide power steering unit bushings between transom plate mounting brackets. Install two pivot bolts and at the same time, slightly move (wiggle) steering unit to ensure proper pivot bolt engagement into bushings. Ensure washer tangs straddle ridges on inner transom plate.

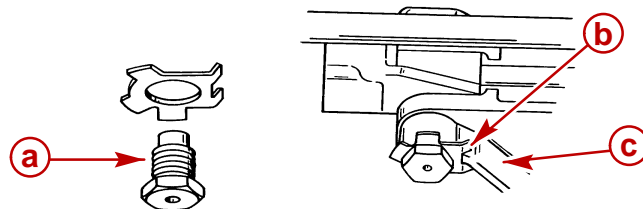
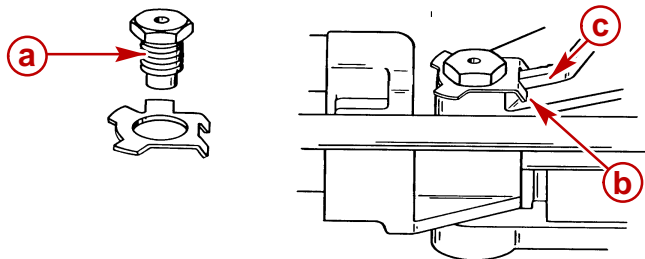

22168

a - Pivot Bolts
b - Washer Tangs
c - Ridges

- c. Torque pivot bolts to 25 lb-ft (34 Nm). Bend washer tabs against flat on bolt heads.
2. If equipped, connect power steering unit clevis to steering lever as follows:
 - a. Lubricate clevis pin with Special Lubricant 101.
 - b. Install clevis pin through clevis and steering lever from top.

- c. Secure clevis pin with cotter pin. Bend both ends of cotter pin.

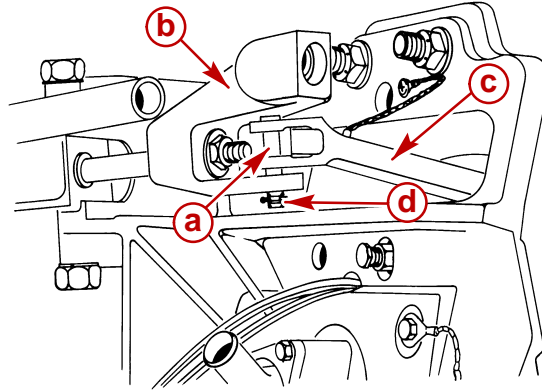

70019

- a - Clevis Pin
- b - Clevis
- c - Steering Lever
- d - Cotter Pin

⚠ WARNING

Failure to use a steering cable locking device could cause a loss of steering, which could cause damage to the boat and/or injury.

All current production Quicksilver Ride Guide steering cables have a self-locking coupler nut and do not require an external locking device. (Other cable manufacturers also make cables with a self-locking coupler nut.)

3. Install steering cable.

- a. Lubricate steering cable end with a liberal amount of Special Lubricant 101 and install cable end through guide tube.
- b. **Later Model Control Valve:** Using a suitable wrench, hold the flat surfaces on the cable guide tube in the vertical position.

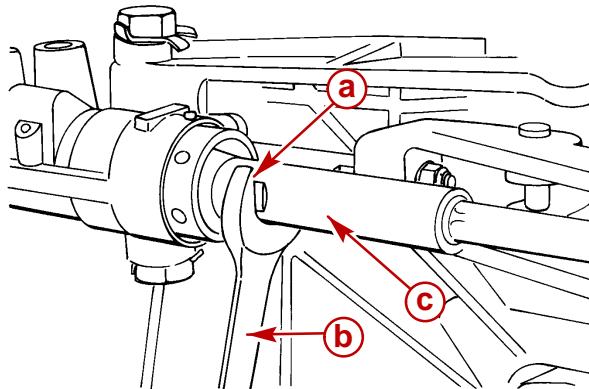

73901

Later Model Control Valve

- a - Flat (Hold Vertical)
- b - Suitable Wrench
- c - Guide Tube

- c. **Both Models:** Connect cable end to clevis with clevis pin. Secure clevis pin in clevis with cotter pin. Bend both ends of cotter pin.

d. Tighten cable coupler nut. Torque to 35 lb-ft (48 Nm).

NOTE: On later models, manually hold the guide tube while tightening the coupler nut.

e. **Earlier Model Control Valve:** If required, install locking plate on coupler nut and secure with screw and washer. Torque to 66 lb-in. (7.5 Nm).

NOTE: Later model control valves DO NOT have a locking plate.

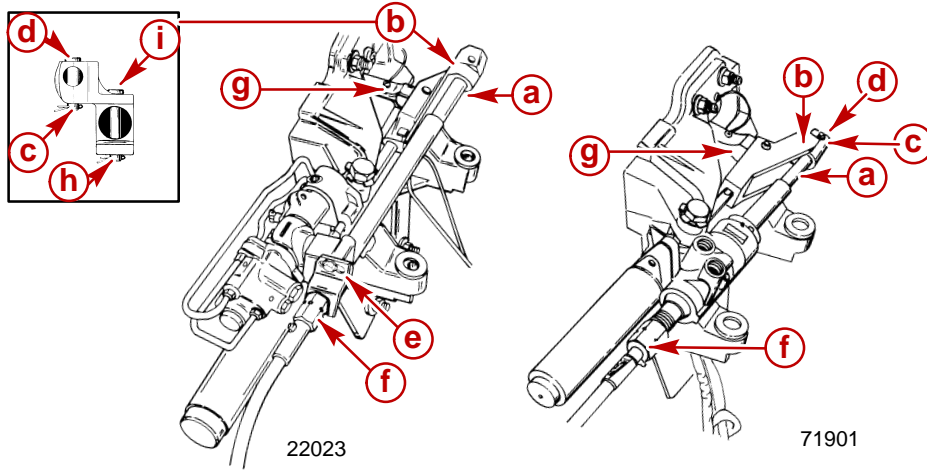

Earlier Model Control Valve **Later Model Control Valve**

- a - Cable End
- b - Clevis
- c - Cotter Pin
- d - Clevis Pin
- e - Locking Plate
- f - Cable Retaining Nut
- g - Steering Lever
- h - Cotter Pin
- i - Clevis Pin

Manual Steering Models

1. Install manual steering assembly on inner transom plate.
 - a. Lubricate swivel ring bushings with Special Lubricant 101.

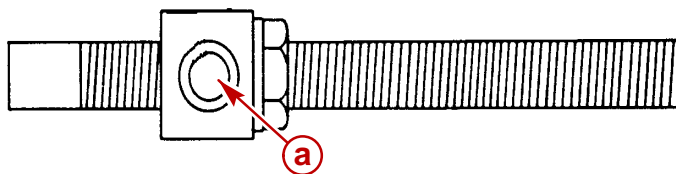

22946

- a - Swivel Ring Bushings

b. Slide manual steering swivel ring and bushings between transom plate mounting brackets. Install two pivot bolts and at the same time, slightly move (wiggle) swivel

ring to ensure proper pivot bolt engagement into swivel ring bushings. Ensure washer tangs straddle ridges on inner transom plate.

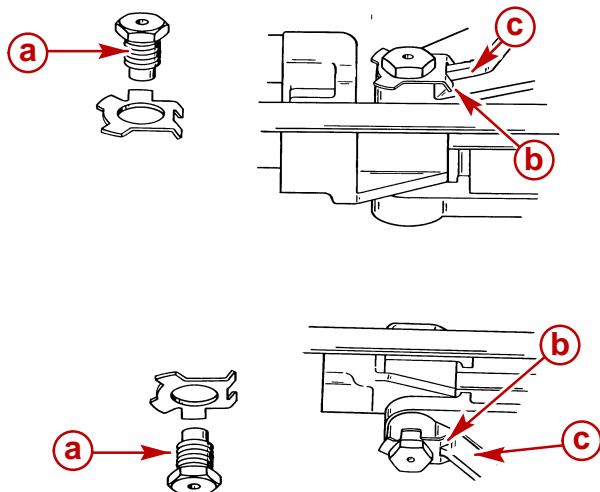

- a** - Pivot Bolts
- b** - Washer Tangs
- c** - Ridges

22168

- c. Torque pivot bolts to 25 lb-ft (34 Nm). Bend washer tabs against flat on bolt heads.
2. Install steering cable.
 - a. Lubricate steering cable end with a liberal amount of Special Lubricant 101 and install cable end through guide tube.
 - b. Connect steering cable to steering lever and secure with clevis pin and cotter pin. Spread both ends of cotter pin.
 - c. Tighten coupler nut. Torque to 35 lb-ft (48 Nm).

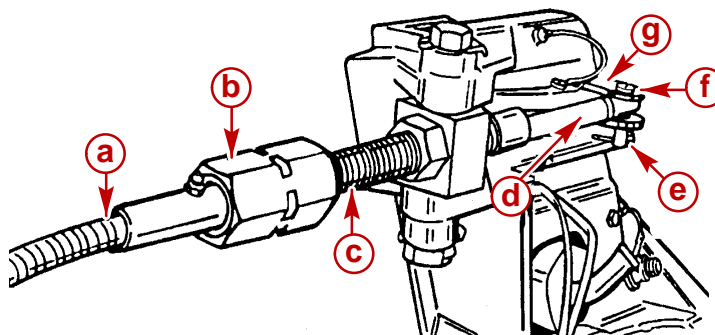

- a** - Steering Cable
- b** - Cable Coupler Nut
- c** - Steering Cable Guide Tube
- d** - Steering Cable End
- e** - Cotter Pin
- f** - Clevis Pin
- g** - Steering Lever

70373

THIS PAGE IS INTENTIONALLY BLANK